

Last modified February 4, 2002

Originally Created by Dr. Mark Tilden and adapted for the WCRG by Dave Hrynkiw

✳ **2002 Rule Changes:**

- *Masking off of solarcell surface area to meet the necessary size requirement is no longer allowe*
- *There and Back Solaroller has been removed (too simple of a challenge!).*

OBJECT:

Given a maximum solar cell size of 806.5 mm² (1.25 square inches), make a self-starting 150mm (6") robot dragster to race one meter (3.3 feet) in full sunlight (or 1,000 watts Halogen lighting). Competitors will race each other down parallel 150mm (6") wide lanes. Fastest to finish, or furthest travelled in 3 minutes wins.

BACKGROUND:

The Solaroller is a deceptively simple device which employs many of the features of small robot design. It is valuable in that it introduces the concept of the self-contained, one-motor-neuron Solarengine, the heart of many BEAM competitors. It is an excellent starter project for future roboticists and can be as minimal or complex as desired, electronically, or mechanically.

The Solarollers only history is that it is a classic type-one roving vehicle as described by Valentino Braitenburg in his book "Vehicles" (1984, MIT Press). That is, a vehicle that only moves forward, its speed proportional to the amount of light it receives on an optical sensor. Although simple conceptually, it can be quite difficult to implement because of the solarcell size restriction 806.5 mm² of even the most efficient solar cell is barely enough to turn most motors, let alone take the strain of actually moving the motor, solarcell, and wheels down a racing lane. This is where the designer learns the value of using what is commonly called an electronic "relaxation oscillator". The idea is to accumulate charge in an electronic storage capacitor while the device is at rest, and then to release it into the drive motor suddenly, causing the device to jump forward in steps. The stored energy spent, the capacitor returns to saving energy for the next time. This can be done using many methods from a simple two transistor circuit (detailed later) to a complex sequencer-FET arrangement.

The problem is that most electronics require between 2 to 5 volts to operate, and most commercial solar cells only produce 0.5 volts. Amorphous solar cells are thereby recommended. These are found in many standard solar-cell calculators, and are characterized by a multi-cellular design; stacking 0.7v cells or stripes adjacent to each other to produce a low efficiency, low current 2 to 5 volts, which is exactly what is required.

The rest is innovation, calculation and solder-skills. The immediate advantage of building such devices is that they can be very small and thus very robust (see figure below). Anyone who has worked with space-quality solar cells knows that they are sharp, expensive, and as fragile as a potato chip. The amorphous cells are, although not indestructible, significantly tougher, cheaper, and easy to work with. Not surprisingly, it is also often cheaper and easier to buy and destroy a whole calculator for its solar cell than to buy the cell separately from a science shop.

Small means tough. No battery means that your Solaroller will only have to worry about mechanical wear and natural corrosion. Once a Solarengine is complete, it can be used for more than just racing. Devices from robot Venus-flytraps to self-turning solar Christmas tree ornaments have been successfully constructed, and competed in various competitions.

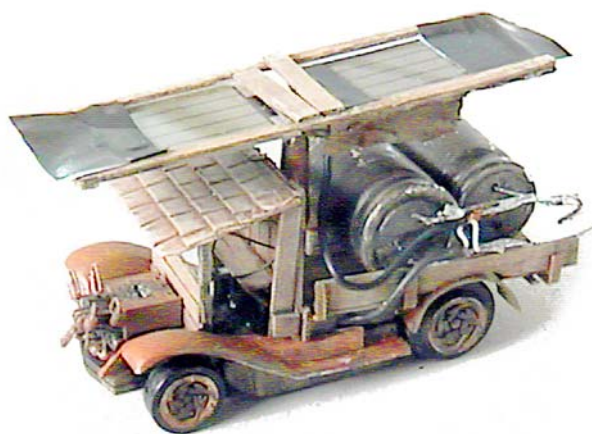

RustMobile, by Jason Fisher (WCRG 2000)

SOLAROLLER

The Solarengine is a counterintuitive learning machine. Most people have learned the simple idea of putting a battery to a motorized toy and then watch it whiz about. By contrast, the Solarengine is quiet, slow, and sedate. However, a robotic device using a battery must eventually have that battery replaced, much to the detriment of the environment (and the device, if the battery leaks). On the other hand, a Solarengine device is slow but persistent, and will continue to work for many years regardless of human intervention. The lifetime is only limited by the years-long decay time of the cell, and the quality of the device's manufacture.

The Solaroller teaches designers to deal with micro amperes of power and efficient mechanical designs from the start. In battery powered toys, a shorted wire could lead to smoke, in a Solaroller, even a 100 kilohm current load is a disastrous energy loss (in a battery powered toy, a high impact crash is inevitable. In a Solaroller, it can only happen if it manages to roll off the shelf. A small leash is recommended).

The solarcells most commonly used for BEAM applications do not generate enough power to drive most DC motors directly - the power generated by the solarcell isn't near enough. It's like trying to start your car with a 9-volt battery; just not enough power output. To get around this limitation, we introduce the Solarengine Circuit. A Solarengine is a simple circuit that stores energy from a solarcell and releases it in a burst to a motor, which than can be turned into useful work (in this case, making a small vehicle move). Many Solarengines use the two-transistor switch approach. That is, there are a pair of transistors that act as a latching switch that when activated, stay on until all the power runs out.

To help out first time Solarengine builders, the following page is a high-detail "Rosetta Stone" for Solaroller construction. Such a device can be put together using the contents of the cheapest solar-cell calculator, a dead walkman, and possibly a radio. There are commercial sources including Solarbotics* , Digikey* , and Radio-Shack*. Chances are you (or a friend) have just these items in the back of a junk drawer, and there is much you can learn just by taking them apart.

The 1381 version of the Solarengine uses (obviously) the Panasonic 1381 Voltage detection chip, which looks much like a regular three-leg transistor. These 1381's were originally designed to monitor the voltage in battery-powered devices like cell phones and pagers, and then shut them off before the battery got to low. We're tricking them into acting in the reverse - turning something on when a particular voltage is reached. It performs the same function as the Flashing LED, but much more efficiently. This means that since the 1381 isn't using up much power "watching" the circuit, more power gets saved in the main storage capacitor.

Unfortunately, the 1381** is harder to get than the Flashing LED**, and is a bit more hassle to build into the Solarengine. But the increase in efficiency more than offsets the increase in construction complexity. Newer technology like this with better solarcells has brought the elapsed times in the Solaroller event down from 15-minute to the point where 45 seconds is now a competitive time to cover the meter distance. Competitor Design Parameters: Solaroller

- 1 At the start of the race, the competing Solarollers potential energy must be zero (0) volts. To insure this, Solarollers must have a pair of shorting wires extending from them far enough to reach a metal shorting bar at the rear of the 150mm (6") starting square. When these wires contact the shorting bar, it must clamp all on-board power storage to zero. Solarollers cannot use any other energy source to motivate them than what they are able to draw from their solar cell. No pre-tensioned springs, elastics, combustion or compressed energy sources are allowed, though any of these may be employed in the design so long as it can be proved that they are at a complete state of rest at the beginning of the run.
- 2 Competitors cannot initially exceed the bounds of a 150mm (6") cube. Competitors may split apart or change their physical geometry beyond the dimensions of this cube during a run, but a win will only count when the LAST part of a shape-changing Solaroller has crossed the finish line. Competitors are not allowed to drop, throw or leave behind any part of their chassis. Competitors must finish with everything they started with.
- 3 Competitors cannot have parts removed or added to them between races with the exception of replacing broken components necessary to the operation of the vehicle. The replacement parts must be identical to the part being replaced, and fact of this be shown to the judge.
- 4 The maximum allowable solar cell surface area cannot exceed 806.5 mm² (1.25 square inches). A 24x33mm, 2.7 volt Panasonic Sunceram BP2433 solarcell shall be considered the norm, except in the case of using a solar-walker, where a 37x33mm 5.5 volt Panasonic Sunceram BP3733 is considered the norm. Any solar-cell configuration will be considered valid so long as the effective cell area does not exceed the maximum allowable. Any solarcell not meeting this requirement will disqualify the device. There is no minimum solar cell size restriction.

- 5 During racing, competitors must not physically touch or attempt to touch each other, however, competitors may attempt to interfere with each others light source by extending vanes or other devices over the 25mm (one inch) lane walls. Vane extensions must still fit within the size guidelines.
- 6 Designers are not allowed to augment their competitor performance by the use of external light sources, or even subtle reflections off of watches or eyeglasses. Devices will be illuminated by a minimum light source of two 500 watt halogen lights placed 50cm (19.7") above the race platform, to a maximum of up to pure noon-time, unobstructed sunlight. In the case of halogen lighting, the first light is placed aimed straight down directly in front of the starting box. The second light is aimed straight down, 66cm (26") from the starting line.
- 7 Competitors should be able to withstand heat excesses up to a radiant 50 C (122 F) from the competition light sources. Melting competitors will be disqualified.

THE COMPETITION PLATFORM:

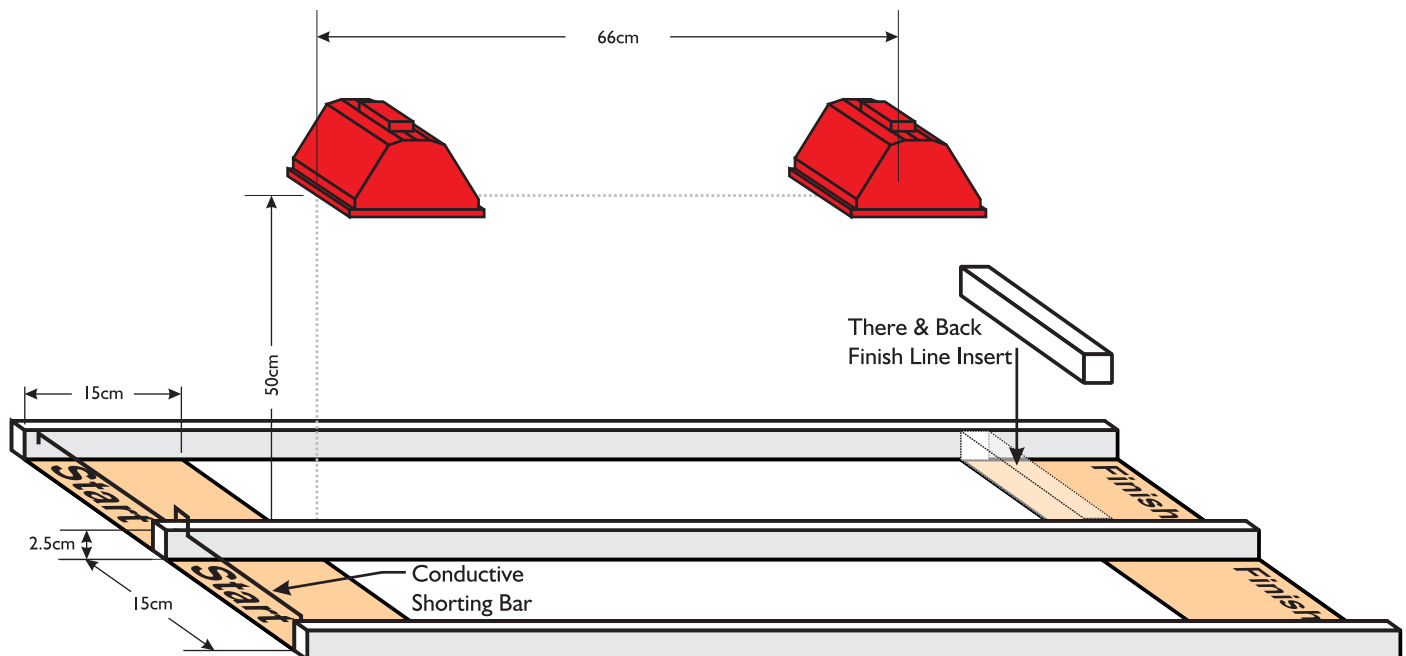

The Solaroller platform

The Racing Platform:

The racing strip is composed of two side by side 1 meter lanes of clean, smooth, level, white melamine, glass mirror, or painted flat plywood, with 25mm (1") high x 12mm (1/2") wide white melamine/arborite walls along both sides of each lane. The lanes will have 150mm (6") between wall surfaces along the full travel length. Competitors start in a 150mm (6") square with their forward edge pushed up to the inside edge of a thin black or white starting line drawn on the walls and surface. One meter away from the start line is the finish line. The finish square is also a 150mm (6") square and has no end wall, except in the case of the "There and Back" competition, where a white wood insert will effectively block the finish square at the finish line.

Due to heat distortion, the walls cannot be guaranteed perfectly straight. Construction methods may result in small cracks in the junction between the floor and walls of the track. Please ensure your design is not susceptible to such cracks.

The light source for the table will be positioned so that no shadows fall from the sides of the vertical walls. Competitors will race into the light source and must be able to optimize a light source from perfectly vertical (90 degrees) to a late afternoon angle (30 degrees). Light may be limited by a single clear window, but otherwise should be unhampered. Due to the possibility of excessive heat buildup, it is advised competitors not use hot glue, soft, black plastics, or wax to hold their solarollers together. Melting has occurred on occasion, and hot glue has been known to weld a racer in place mid-way down the racetrack. The Race:

SOLAROLLER

The single-heat race begins when the judge says “go” and lets a charge build up in the two competitors. This is done by the judge lowering the conductive metal rail at the rear of the starting box that is shorting out the circuitry in the competing racers. Care shall be taken to insure that competitors are released fairly and with as little disturbance as possible. It is the competitor’s responsibility to install suitable wires for this purpose.

Once the contacts are open and the devices allowed to charge, the race has started. To insure the devices follow the “self-starting” rule, competitors must remain immobile for at least three seconds following the start of the race. If one or both move within that time, a false start is called and the race is re-run. If the Solaroller again false-starts, it will be disqualified.

The race is run until the frontmost vertical edge of a competitor crosses the finish line at the end of the 1 meter lane, until a designer concedes, or until a full 3 minutes has elapsed (at which point the racer travelling furthest wins). The exception to this is when a Solaroller changes it’s shape, and must fully cross the finish line.

During the run, competitors are allowed to touch the surrounding walls as necessary but should not damage or climb the walls. If a Solaroller becomes stalled against the wall, it cannot be interfered with. In the case of a dual stall, the furthest travelled competitor shall be considered the winner of that heat.

If clear, unobstructed sunlight is available or the halogen light option is used, the times of the individual runs will be kept track of. All running times shall be registered and recorded.

Scoring:

Eight finalists will be determined by the best-of-two qualifying times if time permits. These top eight will race off in a single-knockout competition, where the Solarollers will race-off in head-to-head heats. When there are only four left, the two pairs will race off. The losers of the race-offs will compete for 3rd and 4th place, and the winners will race for the top position.

** The Panasonic 1381 voltage trigger is available in different voltage-detection thresholds (2.0V to 4.7V) from Solarbotics Ltd., and Digi-Key. The Flashing LED is also available from these places, as well as from local Active Components and Radio Shack stores. ★

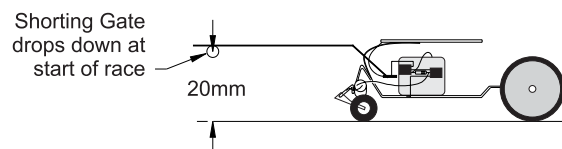
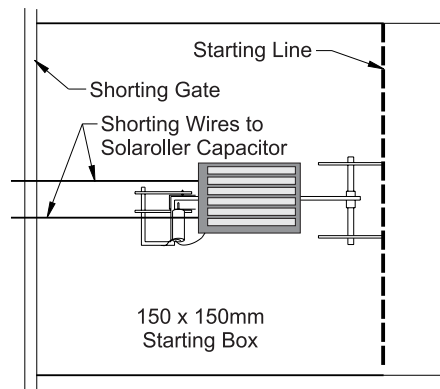

Starting Gate Detail